

User's Guide

for Echo™ Express III-D Desktop Thunderbolt™ 2-to-PCIe Card Expansion Chassis

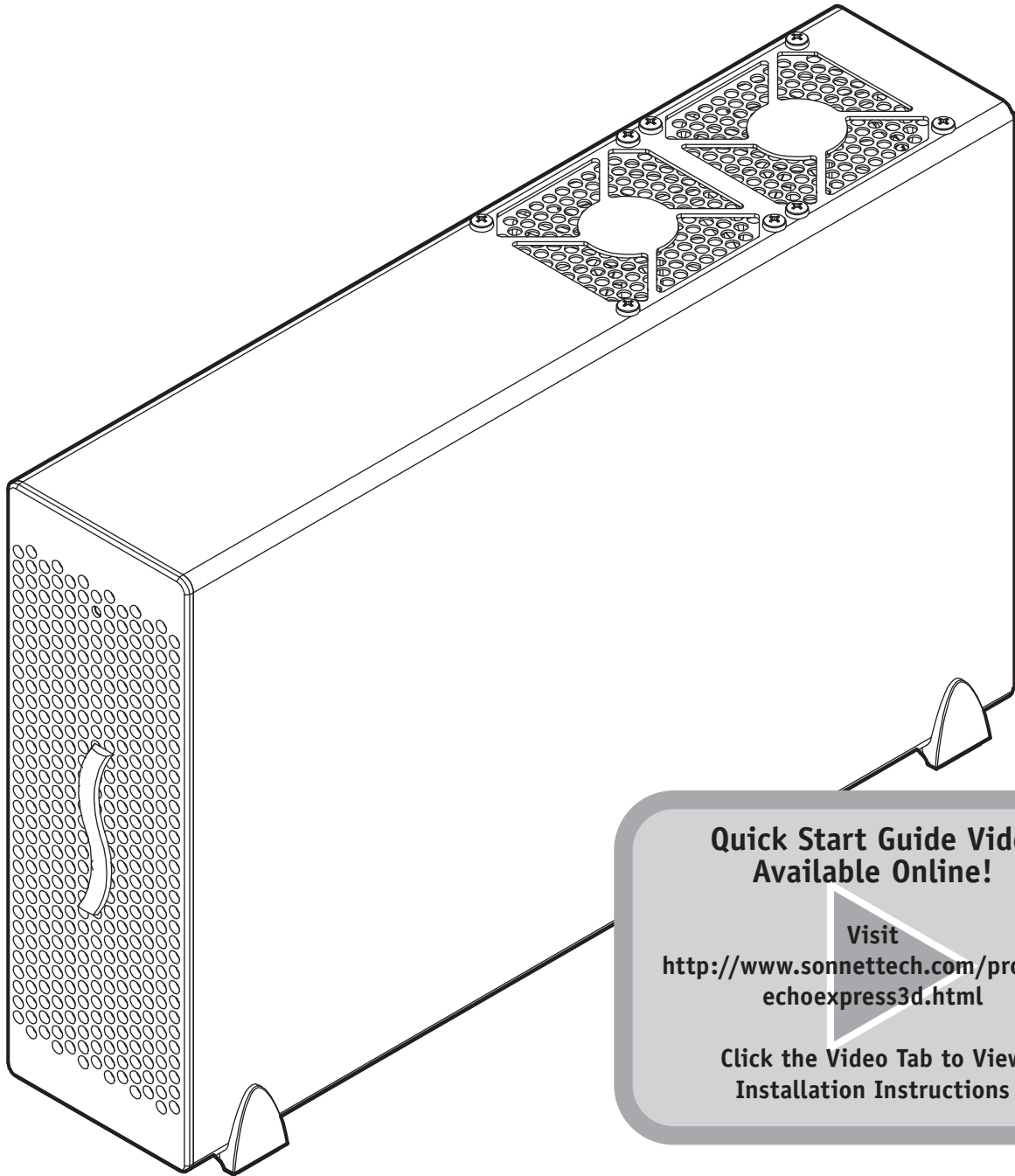

Contents

1	Introduction and System Requirements	1
2	Echo Express III-D Description	2
3	PCIe Card Installation and Chassis Setup Steps	4
4	Verify Connections Using OS X System Information	7
	Verify Echo Express III-D is Recognized	
	Verify Installed Cards are Recognized	
5	Tips, General Information, and Known Issues	8
	Tips, General Information	
	Known Issues	
6	Specifications, Precautions, FCC Compliance, and Support Information	9
	Specifications	
	Safety Precautions	
	FCC Compliance	
	Contacting Customer Service	
	Visit Our Website	
A	BNC Connector Installation Steps	A

This page left intentionally blank

Chapter 1 – Introduction and System Requirements

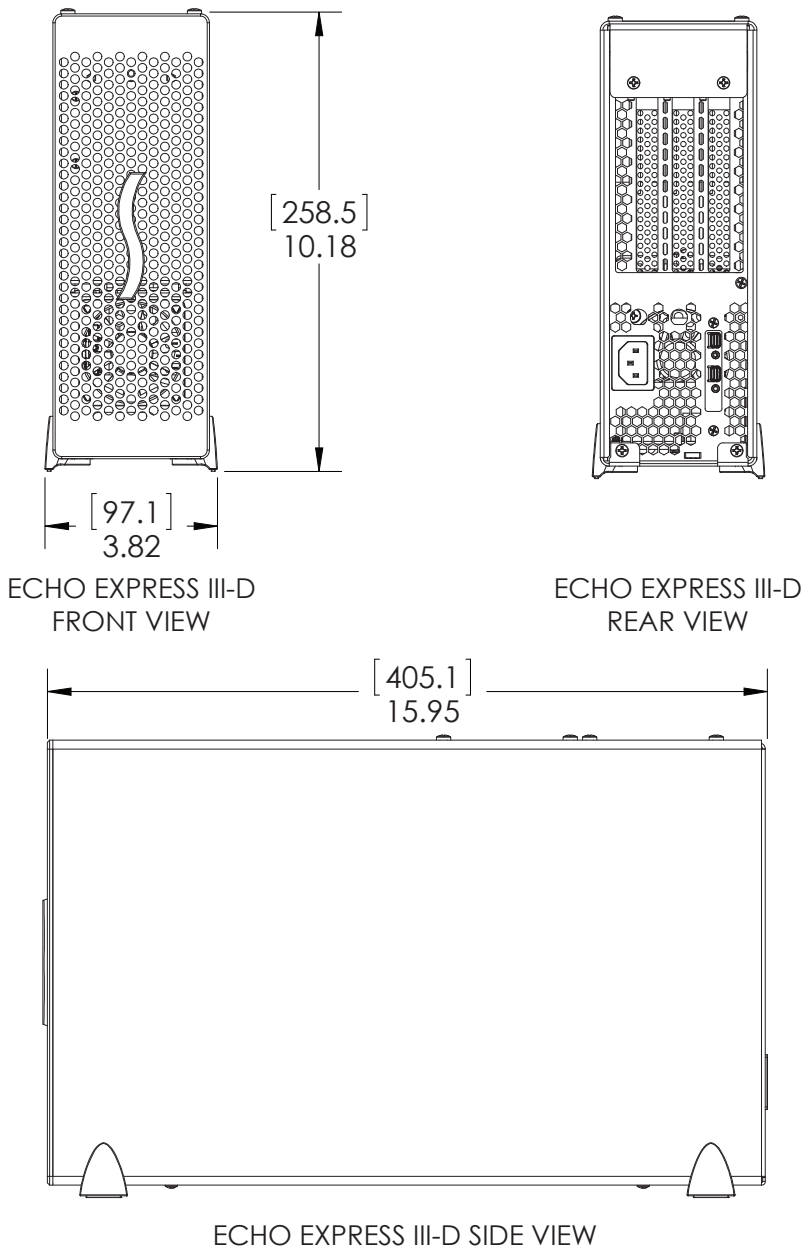

Introduction

Congratulations on your purchase! The Echo Express III-D is a Thunderbolt 2-to-PCI Express card expansion system; through its PCIe slots, you may connect three expansion cards to your Mac® with Thunderbolt technology to expand its capabilities in ways never before possible! With its Windows® support, the Echo Express III-D offers you a handy way to connect expansion cards to your desktop or laptop PC with Thunderbolt technology.

Mac Compatibility

- Mac computer with a Thunderbolt 2 or Thunderbolt port
- OS X® 10.8.5 or later

Windows Compatibility

- Windows PC with a Thunderbolt 2 or Thunderbolt port*
- Windows 8, 7

System Requirements

While the Echo Express III-D chassis requires no drivers, the expansion cards you install do; Thunderbolt-compatible drivers to enable them to work properly through the Thunderbolt interface are required. More information on which cards are compatible with Echo Express III-D is available at: <http://sonnettech.com/support/charts/thunderbolt/index.html>

* To support more than two PCIe controllers, Windows requires a Thunderbolt 2 interface in both the computer and the expansion chassis. Note that some PCIe cards have a bridge to multiple controllers, so it is possible for a single dual-controller PCIe card to reach the limit if not connected via Thunderbolt 2. Not all Mac-compatible PCIe cards are also compatible with Windows.

Chapter 2 – Echo Express III-D Description

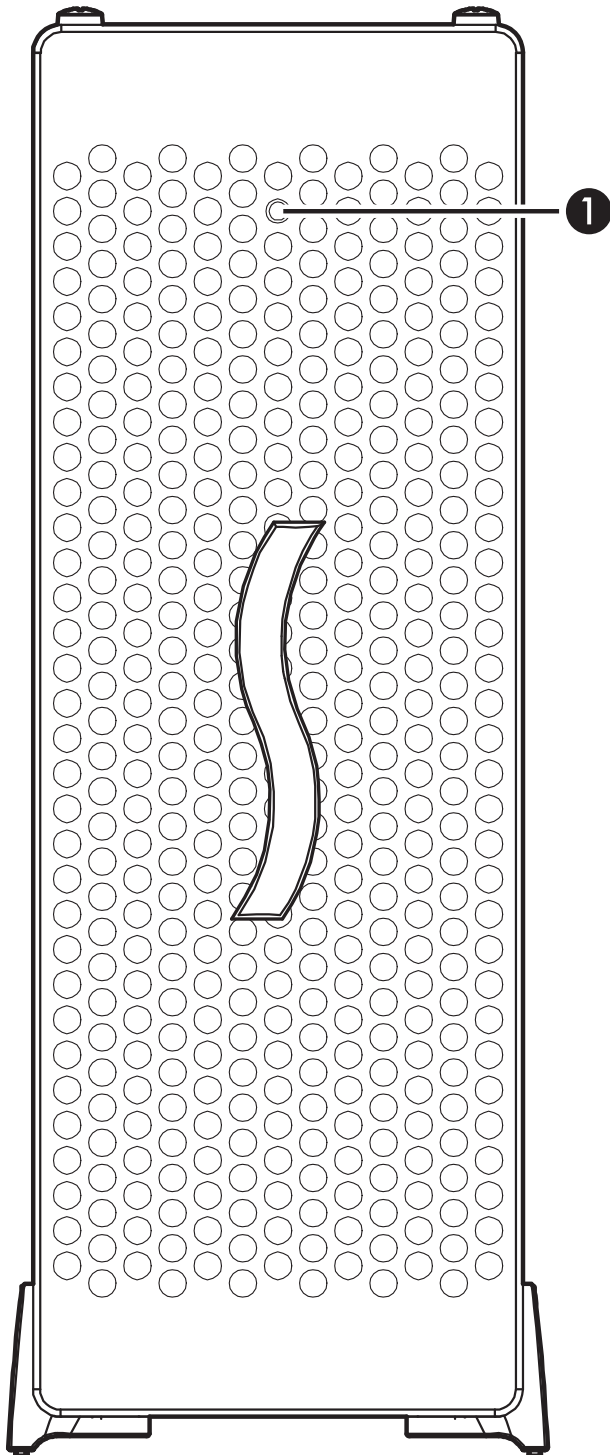

1 – Power Indicator LED

This lights when the Echo Express III-D is powered, the Thunderbolt cable between the chassis and your computer is plugged in securely, and the computer powered on.

2 – BNC Connector Mounting Holes

These accommodate the installation of BNC connectors like those used for HD/SDI output for the RED ROCKET-X transcoding card, or for MADI and word clock input and output from cards like RME's HDSPe MADI FX.

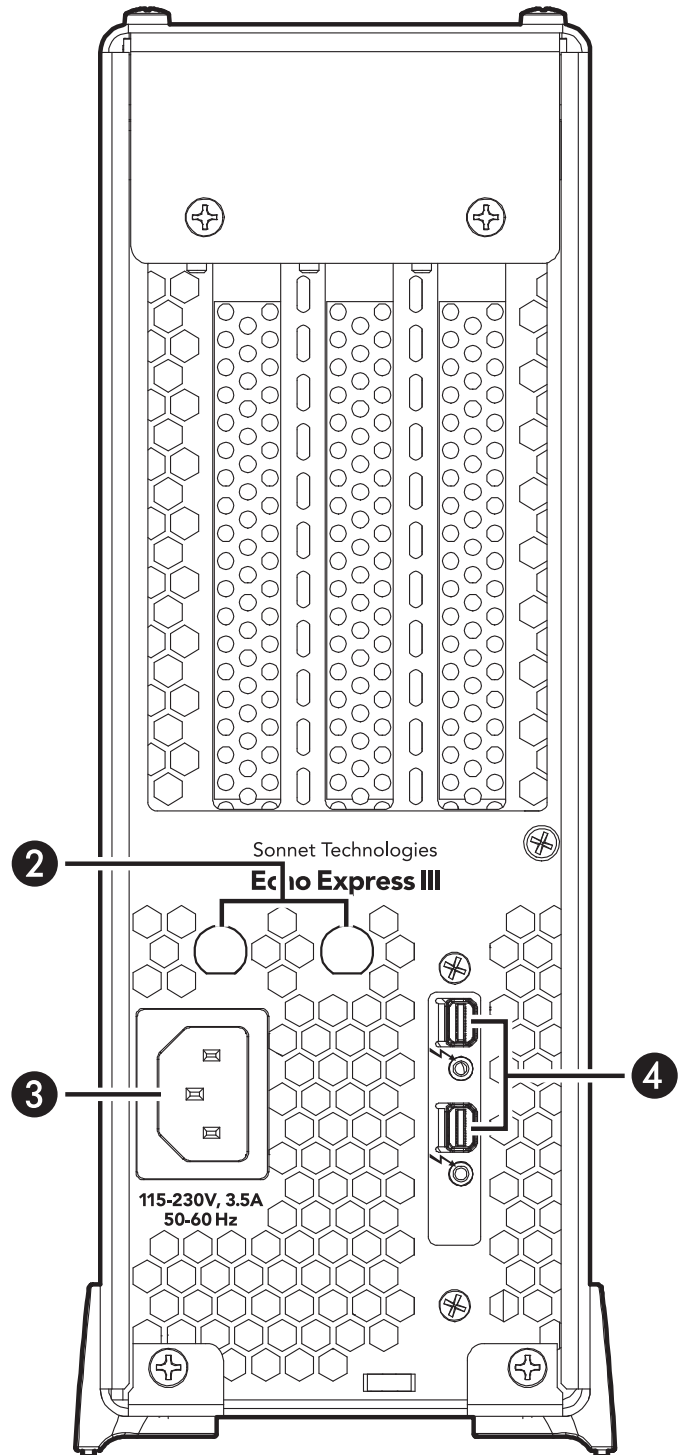

3 – Power Input Socket

Connect the included AC power cable here.

4 – Thunderbolt Ports

Connect a Thunderbolt cable between either port and your computer's Thunderbolt port (or other Thunderbolt device in the chain connected to the computer); the other may be used to connect to another Thunderbolt device.

Chapter 2 – Echo Express III-D Description

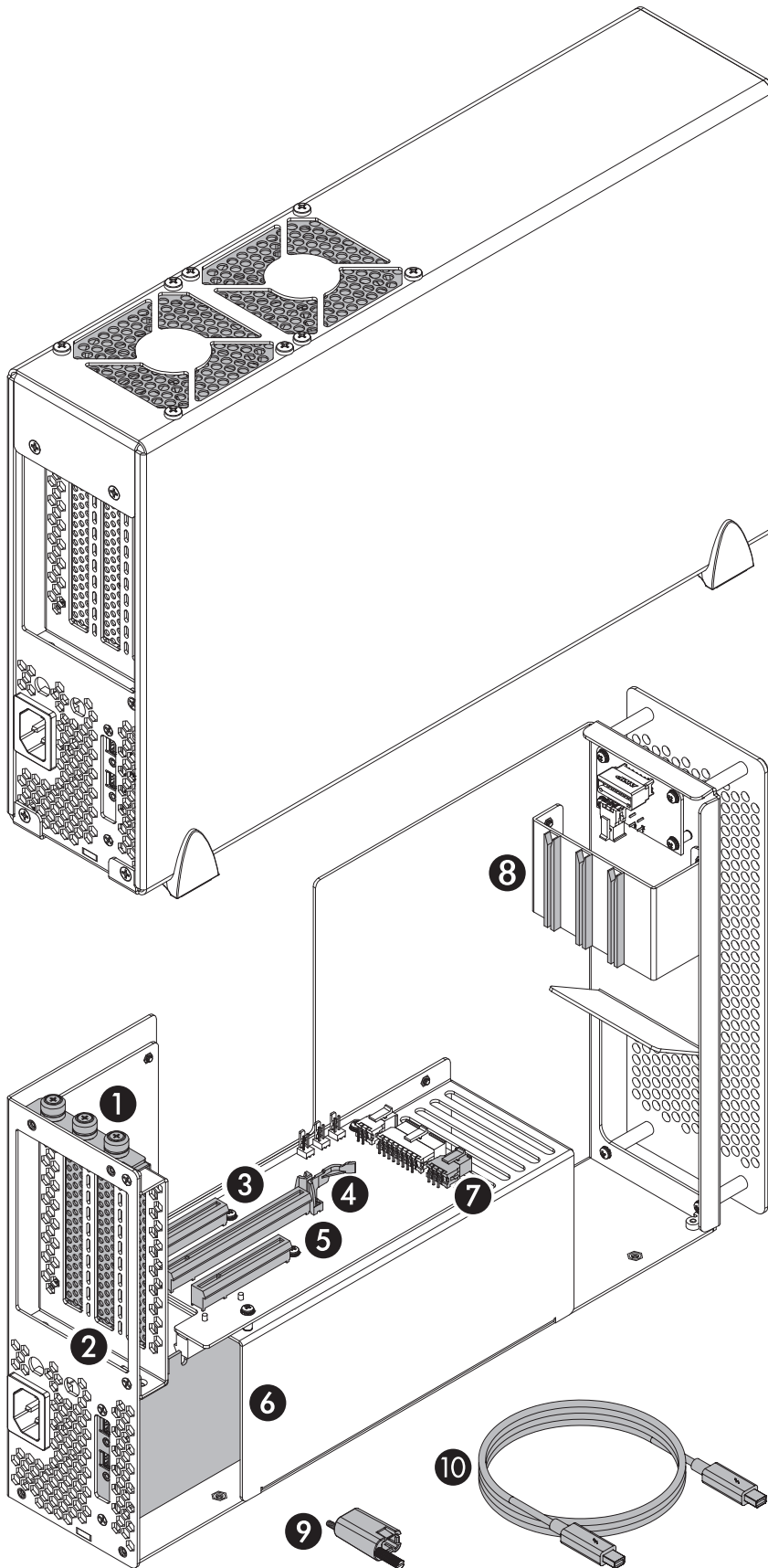

Outer Case

Temperature-Controlled Fans

These provide cooling for the installed PCIe cards and the chassis' supporting Thunderbolt circuitry. They operate at a whisper when the cards are running cool, and automatically speed up in steps as the temperature rises. Do not block the fans or the vent holes on the front or back of the chassis to prevent overheating.

Inner Assembly

1 – PCIe Card Bracket Locking Plate

This secures installed PCIe cards and port access covers in place.

2 – Port Access Covers

These cover openings in the chassis when PCIe slots are unoccupied.

3 – Slot 1

This is an x8 electrical (x8 mechanical) PCIe 2.0 slot. It is also compatible with PCIe 1.1 and 3.0 cards.

4 – Slot 2

This is an x8 electrical (x16 mechanical) PCIe 2.0 slot. It is also compatible with PCIe 1.1 and 3.0 cards.

5 – Slot 3

This is an x4 electrical (x8 mechanical) PCIe 2.0 slot. It is also compatible with PCIe 1.1 and 3.0 cards.

6 – Thunderbolt Interface Card

This card is installed in its own slot and may not be moved to another slot.

7 – 6-Pin Auxilliary Power Connector

Plugged into this connector is the auxiliary power cable for cards requiring extra power, such as the Avid Pro Tools|HDX or RED ROCKET-X.

8 – PCIe Card Guides

When installing full-length cards, use these to support and secure the cards.

9 – Thunderbolt Connector Retainer Clip

This secures a Thunderbolt connector plugged into the Echo chassis' Thunderbolt port to prevent accidental cable disconnection. This clip is not compatible with optical Thunderbolt cables.

10– Thunderbolt Cable

Connect this cable between the Echo chassis and your computer (or other Thunderbolt device in the chain connected to the computer).

Chapter 3 – PCIe Card Installation and Chassis Setup Steps

1. Remove the Echo Express III-D from its packaging, and then set it on a flat, level surface.
2. Using a Phillips screwdriver, remove and set aside the four screws securing the back of the outer case to the inner assembly (**Figure 1**).
3. Turn the Echo chassis on its side.
4. Remove and set aside the four screws securing the bottom of the outer case to the inner assembly (**Figure 1**).
5. Tilt the Echo chassis upright.
6. Grasping the outer case with one hand, push the inner assembly into the outer case, and then gently pull out the inner assembly (**Figure 1**). Set aside the outer case.

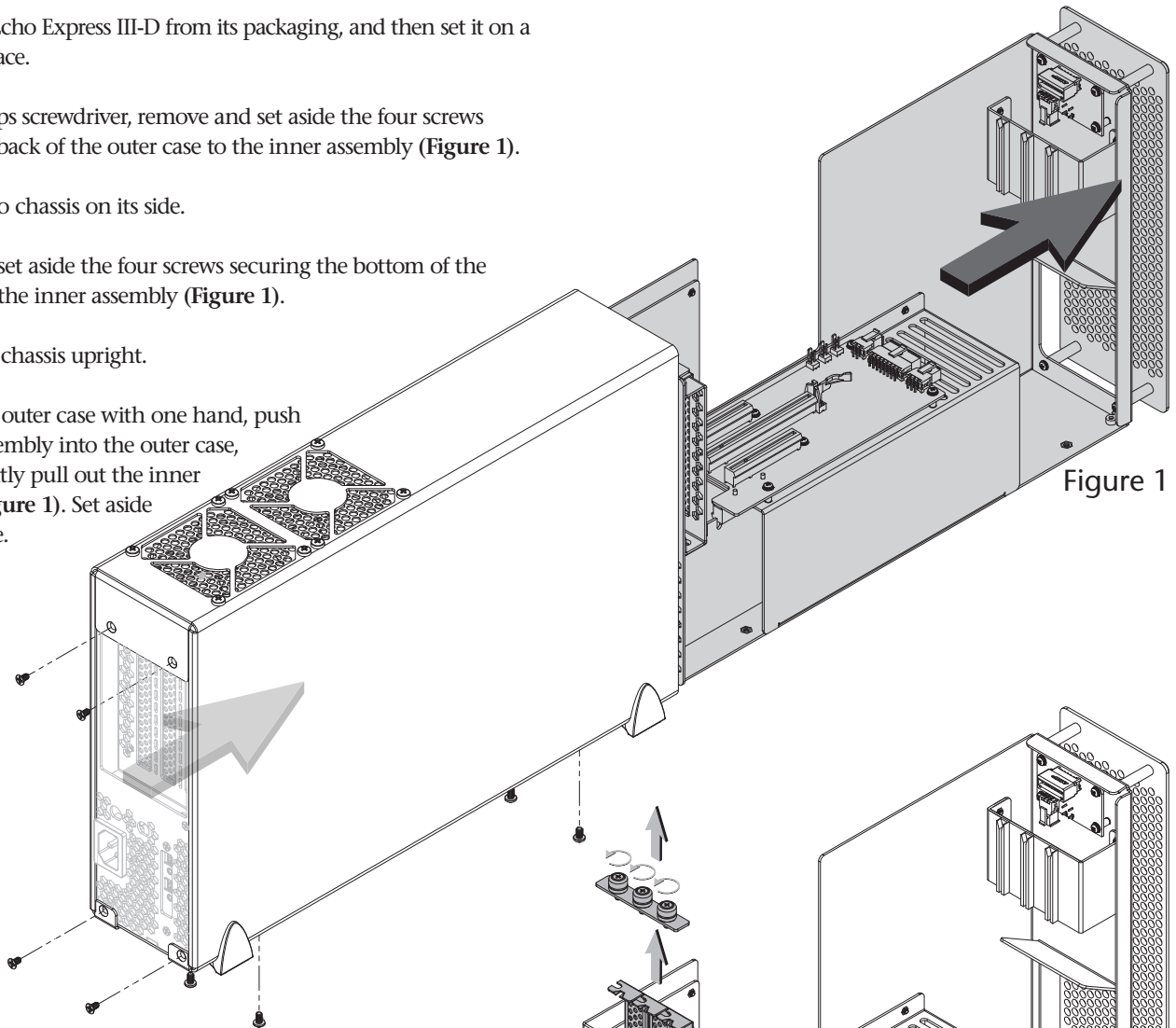

Figure 1



Support Note: To avoid damaging components due to static electricity discharge, wear an antistatic wrist strap while working inside the Echo Express chassis.

7. Loosen all three thumbscrews of the PCIe card bracket locking plate, and then remove and set it aside (**Figure 2**).
8. Remove and set aside the port access covers (**Figure 2**).

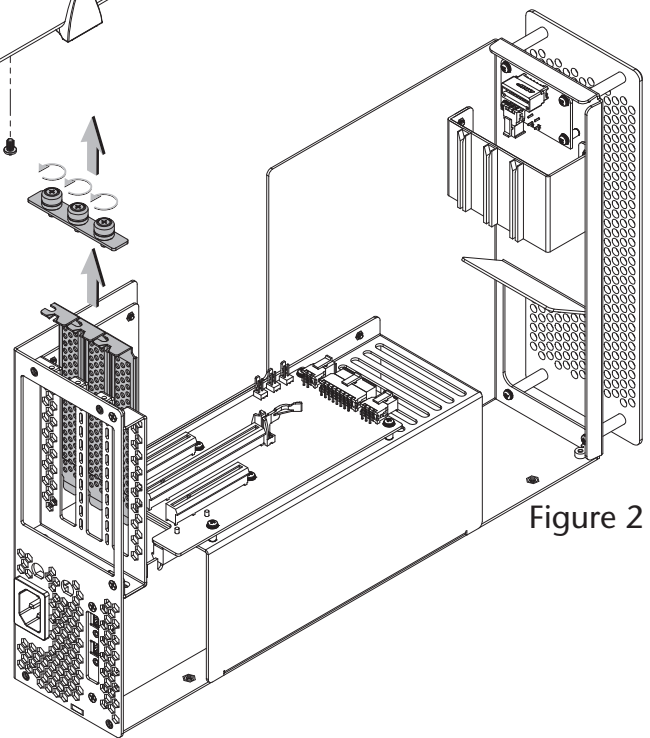

Figure 2

WARNING: When handling computer products, take care to prevent components from being damaged by static electricity; avoid working in carpeted areas. Handle expansion cards only by their edges and avoid touching connector traces and component pins. Also, avoid touching the Echo chassis' circuit boards and any of its components.

9. **OPTIONAL STEP:** If you are installing a PCIe card which requires auxiliary power, locate the wire harness connected to the 6-pin connector indicated in the graphic to the right (**Figure 3**). Remove the cable twist tie securing the wire harness, and move the loose connector aside for later connection. Otherwise, go to the next step.

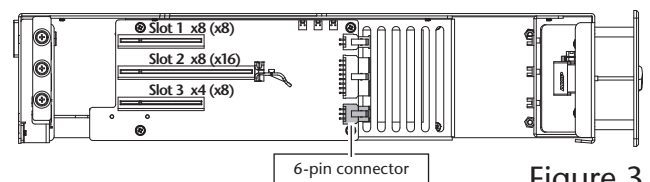

Figure 3

Chapter 3 – PCIe Card Installation and Chassis Setup Steps



Support Note: If you are installing an Avid Pro Tools|HDX PCIe card, you will need to disconnect the Echo chassis' auxiliary power wire harness plugged into the 6-pin connector indicated in **Figure 3**, and replace it with the one included with the Avid card.

10. OPTIONAL STEP: If you are installing BNC connectors into the chassis' mounting holes, skip to the appendix at the end of this document for instructions. Otherwise, go to the next step.
11. Remove a PCIe card from its packaging, handling the card by its edges and without touching any components or gold connector pins.



Support Note: If you are installing an x8 PCIe 1.1 card like the original Red Rocket (not Red Rocket-X), or certain 10 Gigabit Ethernet cards, installing it into slot 3 may result in reduced performance. We recommend you install it into either slot 1 or 2 for best performance.

12. Line up the card's connector with the slot, and then gently but firmly press the card straight into the slot; **do not rock the card or force the card into the slot**. If you encounter excessive resistance, check the card's connector and the slot for damage, and then try inserting the card again (**Figure 4**).

13. Repeat steps 11 and 12 as necessary with any remaining cards.

14. If you installed a card which requires auxiliary power, connect the auxiliary power connector to it now. If you installed cables with BNC connectors into the chassis, connect them to the card you installed.

15. If there are any unoccupied slots, install the port access covers you removed previously (**Figure 4**).

16. Secure the cards and port access covers using the previously-removed PCIe card bracket locking plate (**Figure 4**).

17. Grasping the outer case, gently push the inner assembly back inside, and then secure the outer case to the inner assembly using the eight screws you removed previously; **do not overtighten the screws** (**Figure 5**).

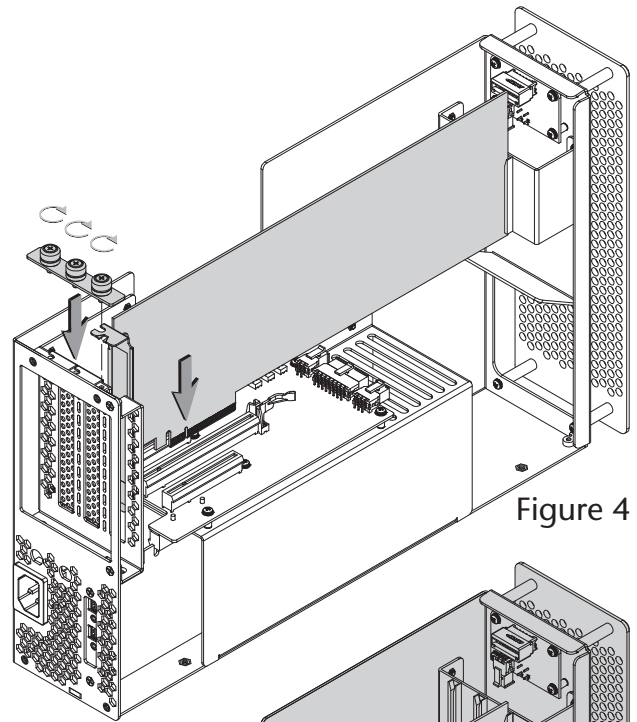

Figure 4

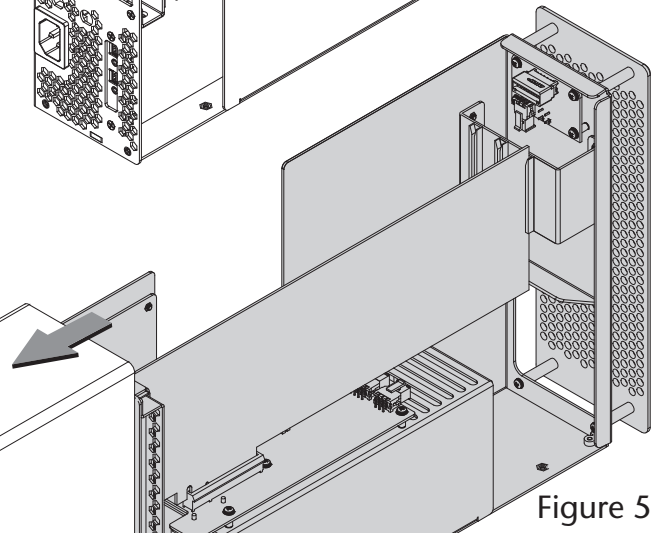

Figure 5

Chapter 3 – PCIe Card Installation and Chassis Setup Steps



Support Note: Sonnet's ThunderLok™ Thunderbolt connector retainer clip secures the included Thunderbolt cable to the Echo chassis to prevent accidental disconnects. Although it is compatible with other copper Thunderbolt cables like Apple's, it is not compatible with optical Thunderbolt cables.

To attach the clip to the cable, remove them from their packaging, and then insert the connector into the connector clip as shown (**Figure 6**). Note that the connector will pass all the way through the clip; when you connect the cable to the chassis, the clip will secure the cable.

18. Connect the included Thunderbolt cable between either Thunderbolt port on the Echo chassis and a Thunderbolt port on your computer, or other Thunderbolt device in the chain connected to the computer (**Figure 6**). Secure the retainer clip to the chassis if you attached it. If you are daisy chaining additional Thunderbolt devices, connect another Thunderbolt cable between the downstream device and the open Thunderbolt port on the Echo chassis.
19. Connect interface cables between devices, PCIe cards, and computer as necessary.
20. Connect the included power cord between a wall outlet or power strip and the Echo chassis' power socket. Note that the power indicator on the Echo Express III-D will not light until the computer, and any other Thunderbolt device connected between it and the Echo chassis, is powered on.

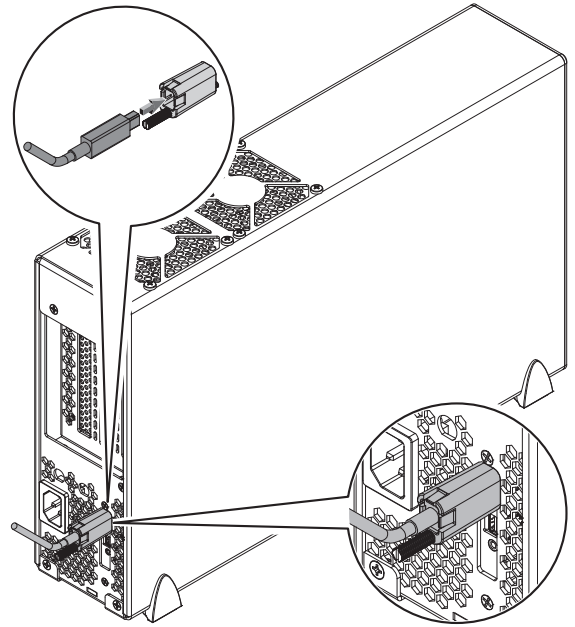



Figure 6

Chapter 4 – Verify Connections Using OS X System Information

A – Verify the Echo Express III-D is Recognized

1. With the Echo chassis powered and connected to the computer, turn on the computer.
2. From the Apple menu, select About This Mac; the System Information application will launch.
3. When the *About This Mac* window opens, click More Info; a summary of specifications will appear.
4. Click System Report; a full report window will appear.
5. In the *System Information* window, click Thunderbolt under the Hardware header in the left column (Figure 8).
6. In the top right column under the Thunderbolt Device Tree header, you will see the computer, followed by “Echo Express III” (Figure 8).

 **Support Note:** If “Echo Express III” is not listed, disconnect and reconnect the Thunderbolt cable between the computer and Echo chassis. Note that it is not necessary to shut down the computer before disconnecting and reconnecting the cable.

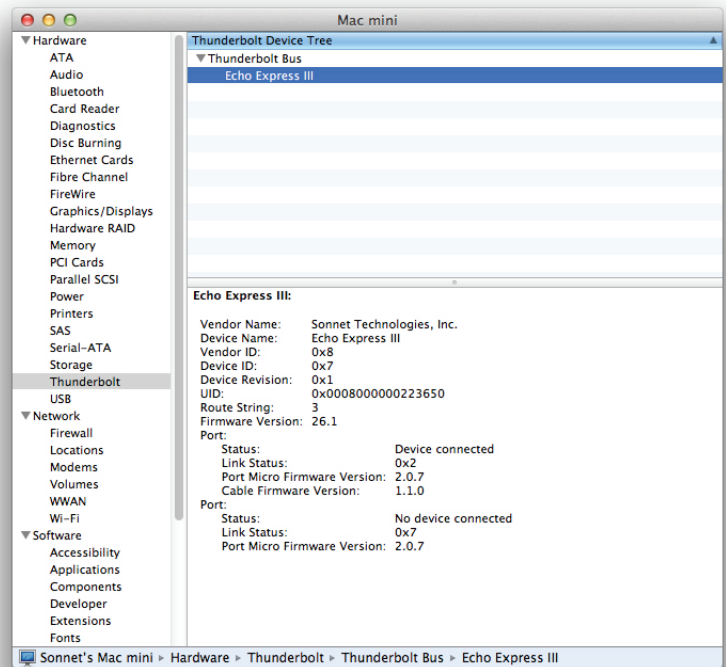



Figure 8

B – Verify Installed Cards are Recognized

1. When a card is installed into one of Echo chassis' PCIe slot(s), the PCIe slot (listed as a port), the Status should appear as connected.
2. Click PCI Cards under the Hardware header in the left column (Figure 9).
3. At the top of the right column, installed cards are listed. By selecting a card at the top, detailed information is listed. You should see “Yes” next to Driver Installed and Tunnel Compatible, otherwise the card or driver may not be Thunderbolt compatible (Figure 9).

 **Support Note:** While Echo Express expansion chassis require no drivers, installed cards require Thunderbolt-compatible drivers to enable their use.

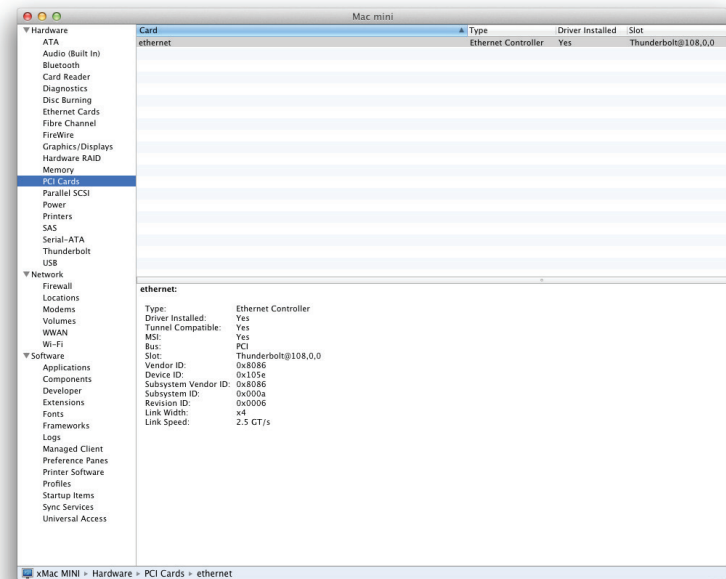

Figure 9

Chapter 5 – Tips, General Information, and Known Issues

TIPS, GENERAL INFORMATION

Keeping the Cards Cool

With its optimized airflow design and temperature-controlled fans providing cooling at all times, Echo Express III-D provides adequate cooling for the installed cards. *Do not operate the Echo Express III-D with the outer case removed, and do not block any of the vents!* Otherwise, the installed cards and Echo Express' components may overheat.

Hot Plugging the Echo Express Expansion Chassis

When certified Thunderbolt-compatible cards (used with Thunderbolt-compatible drivers) are installed in Echo Express III-D, you may connect and disconnect the chassis while the computer is on. Of course, if you have anything connected to the cards, such as storage devices, cameras, etc., follow proper procedures for disconnecting those devices before unplugging the Echo Express chassis.

There's No Need to Unplug the Power Cable

Because Echo Express automatically powers on and off with the computer to which it's connected, there's no power switch, nor is there any need to disconnect the power cable under normal use.

Power Indicator LED Operation

Because Echo Express automatically powers on and off with the computer to which it's connected, the power indicator LED only turns on when the computer is on, and turns off when the computer is sleeping or powered off.

Connecting Additional Thunderbolt Devices

You may connect up to six Thunderbolt devices total in a daisy chain, including the Apple Thunderbolt Display.

Using Expansion Cards Without Drivers

Some Thunderbolt-compatible expansion cards, like Sonnet's Allegro™ FW800 PCIe FireWire® adapter and Sonnet's Tempo™ SATA Pro 6Gb eSATA cards, use drivers built into the OS.

Replacing Cards or Adding Cards After Initial Installation

If you decide to replace or add a card to Echo Express after the initial setup, shut down the computer, and then disconnect the power cord and Thunderbolt cables before installing a card.

KNOWN ISSUES

Not all PCIe Cards Will Perform at 100%

Thunderbolt 2's PCIe bandwidth is limited to 20Gbps. While many cards will operate at full performance, some may not due to the fact they require more bandwidth than Thunderbolt 2 is capable of delivering.

OS X Updates May Break Compatibility

Specific device drivers that work under one version of OS X may not work under a later version. *Before updating to the latest OS, we recommend that you contact your PCIe cards' manufacturers to verify that the existing drivers work with the new OS version.* Note that other software updates for the computer may also break compatibility.

Some Devices' Performance May be Affected by Where They Are Connected in a Thunderbolt Chain

However small, Thunderbolt introduces latency to a device chain. If you expand with additional Thunderbolt expansion chassis, you may need to experiment with which cards work better in chassis closer to or farther from the computer in the chain.

PCIe CARDS ARE NOT HOT-PLUGGABLE!

Never install a PCIe card into Echo Express while it is connected to a computer or power outlet! If you do, you risk injury, and damage to the card, chassis, and computer.

Chapter 6 – Specifications, Precautions, FCC Compliance, and Support Information

Specifications

External Connectors	Two Thunderbolt 2 Power (C14-type)
PCIe 2.0 Expansion Slots	<ul style="list-style-type: none">• One x8 mechanical (x8 electrical)• One x16 mechanical (x8 electrical)• One x8 mechanical (x4 electrical)
PCIe Cards Supported	<ul style="list-style-type: none">• One full length, full-height, double-width PCIe card, plus one single-width card or <ul style="list-style-type: none">• Three full length, full-height, single-width PCIe cards
Compatible PCIe Cards	See Sonnet Website (www.sonnettech.com)
Power Supply	Universal 300W, 115-230V AC, 50-60 Hz ⁽¹⁾
Operating Temperatures	0° C to 35° C (32° F to 95° F)
Dimensions WxDxH	3.8 x 16 x 10.2 in. (9.7 x 40.5 x 25.9 cm)
Weight (Echo Express Pro)	7.5 lbs (3.4 kg)
RoHS Compliant	Yes
Package Contents	<ul style="list-style-type: none">• Echo Express III-D chassis• Power cord• Thunderbolt cable• ThunderLok Thunderbolt connector retainer clip⁽²⁾• User's guide

1. Power supply will operate at 90-115V AC, with linear power deration of 240W-300W over that range.

2. Not compatible with optical Thunderbolt cables.

SAFETY PRECAUTIONS

Please read this section carefully before proceeding. These precautions explain the correct and safe use of this device, thereby helping to prevent injury to you or others, and also help you to minimize the risk of damaging the device.

Warnings

Always follow the basic warnings listed here to avoid the risk of serious injury or death from electrical shock, short-circuiting, fire, and other hazards. These warnings include, but are not limited to:

- Do not attempt to modify the enclosure. If this device appears to be malfunctioning, contact your reseller or local distributor.
- Do not drop the chassis; dropping or mishandling chassis may result in a malfunction leaving the product inoperable.
- Do not insert your fingers or foreign objects inside the slot(s).

Warnings (continued)

- Do not expose the device to rain, use it near water or containers that contain liquids which might spill into any openings, or in damp or wet conditions.
- If unusual smells, sounds, or smoke come from the device, or if liquids enter it, unplug it from the electrical outlet immediately.
- Follow the instructions in this manual carefully; contact your reseller or local distributor for additional advice not covered in this User's Guide.

FCC Compliance

Echo Express III complies with Part 15 of the FCC Rules. Operation is subject to the following two conditions: This device may not cause harmful interference, AND this device must accept any interference received, including interference that may cause undesired operation.

Contacting Customer Service

The Sonnet Web site located at www.sonnettech.com has the most current support information and technical updates. Before you call Customer Service, please check our Web site for the latest updates and online support files, and check this User's Guide for helpful information.

When you call Customer Service, have the following information available so the customer service staff can better assist you:

- Product name
- Date and place of purchase
- Computer model
- PCIe card models
- Operating system version
- Software/firmware versions

USA Customers

If further assistance is needed, please contact **Sonnet Customer Service** at:

Tel: 1-949-472-2772

(Monday–Friday, 7 a.m.–4 p.m. Pacific Time)

E-mail: support@sonnettech.com

For Customers Outside the USA

For support on this product, contact your reseller or local distributor.

Visit Our Web Site

For the most current product information and online support files, visit the Sonnet Web site at www.sonnettech.com/support/. Register your product online at <http://registration.sonnettech.com> to be informed of future upgrades and product releases.

Appendix A – BNC Connector Installation Steps

1. Remove and set aside the two screws securing the Thunderbolt interface card to the inner assembly (**Figure A-1**).
2. Gently push down on the edge of the card to disengage the card from its slot (**Figure A-1**).

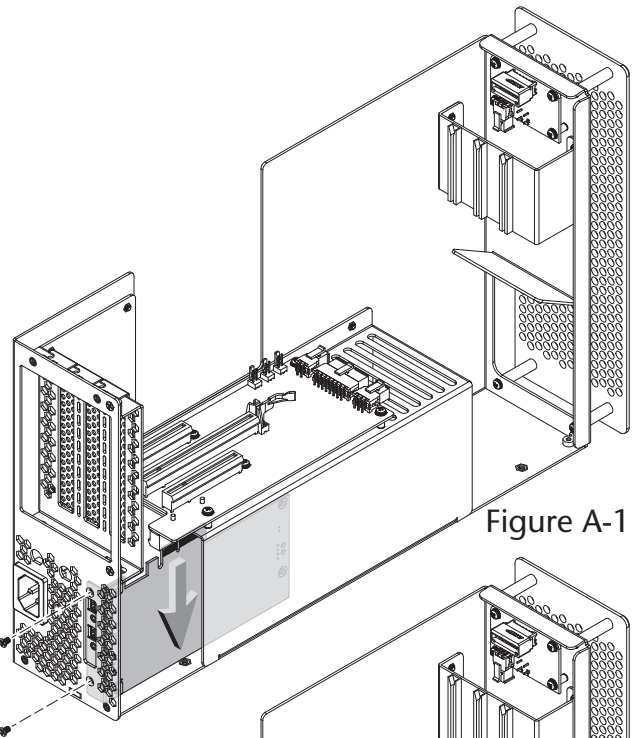

Figure A-1

3. Grasping the card by its edges, rotate the bracket out of the inner assembly, and then pull out the card (**Figure A-2**). Set aside the Thunderbolt interface card on flat surface, component side down.

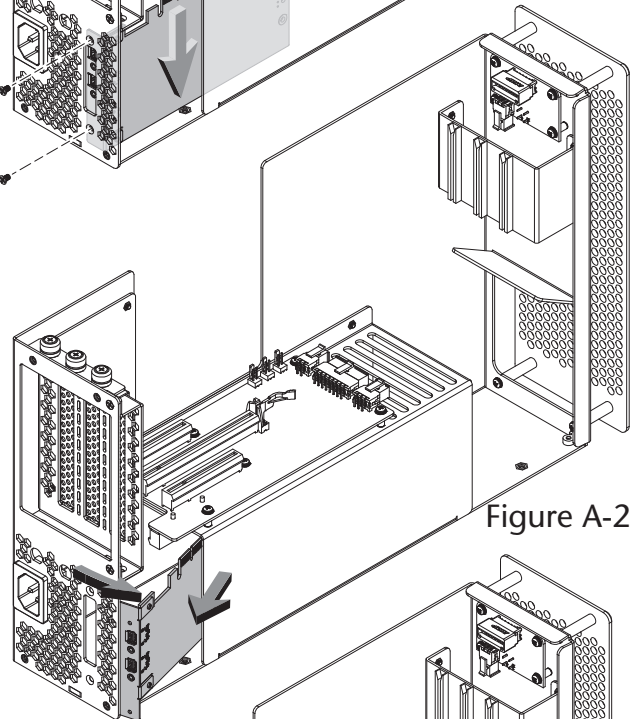

Figure A-2

4. Insert the BNC cables through the BNC connector mounting holes in the inner assembly (**Figure A-3**). Route the cables out over the top of the PCIe slot riser card.
5. Slide the connector nuts over the BNC cables, and then secure the connectors to the inner assembly (**Figure A-3**).

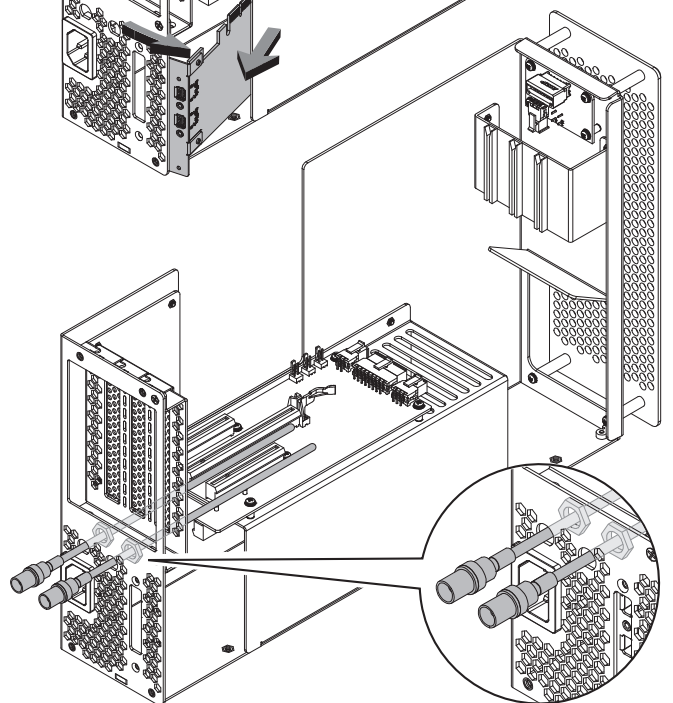

Figure A-3

Appendix A – BNC Connector Installation Steps

6. Grasping the Thunderbolt interface card by its edges, insert the card back into the inner assembly (Figure A-4).

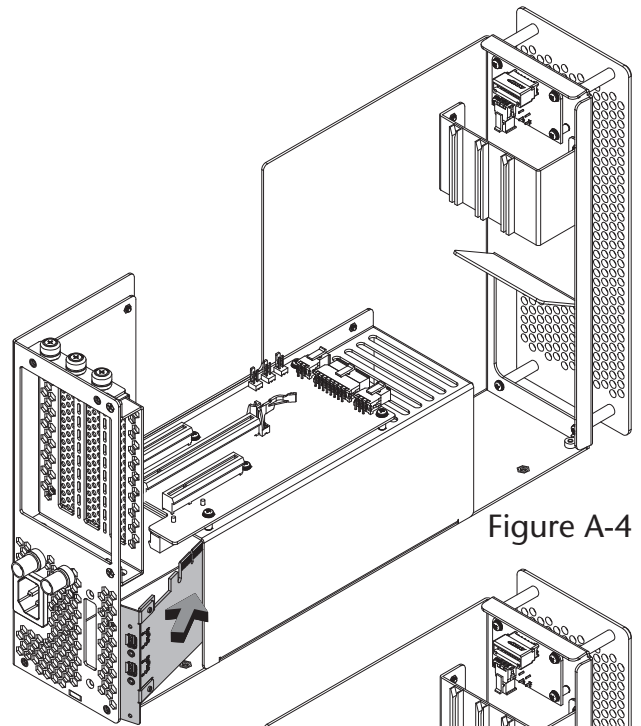

Figure A-4

7. Line up the card's connector with the slot, and then gently but firmly press the card straight into the slot; **do not rock the card or force the card into the slot**. If you encounter excessive resistance, check the card's connector and the slot for damage, and then try inserting the card again (Figure A-5).

8. Using the two screws you removed previously, secure the Thunderbolt interface card to the inner assembly; **do not overtighten the screws** (Figure A-5).

9. Return to step 11 on page 5 to complete the PCIe card and chassis setup steps.

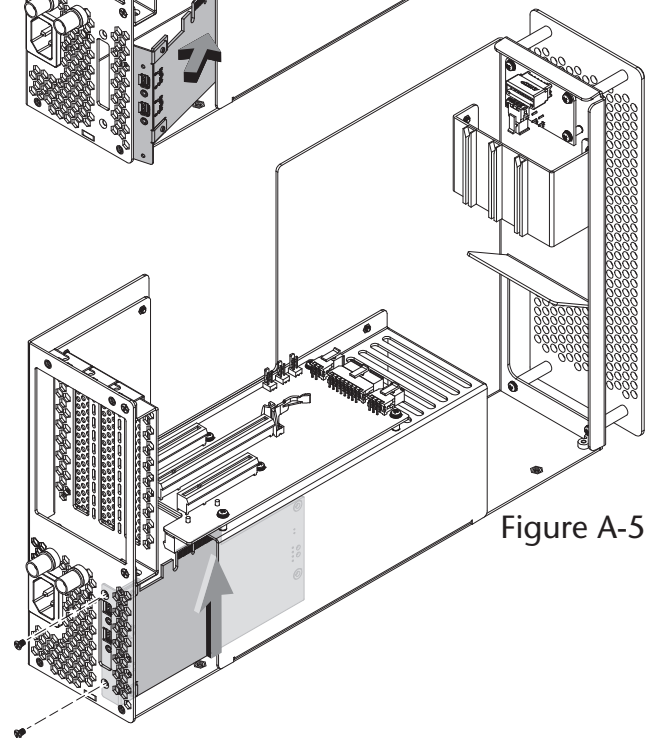

Figure A-5



©2015 Sonnet Technologies, Inc. All rights reserved. Sonnet, the Sonnet logotype, Simply Fast, the Simply Fast logotype, Allegro, Echo, and Tempo are trademarks of Sonnet Technologies, Inc. FireWire, Mac, the Mac logo, and OS X are trademarks of Apple Inc., registered in the United States and other countries. Thunderbolt 2 and the Thunderbolt logo are trademarks of Intel Corporation in the U.S. and/or other countries. Other product names are trademarks of their respective owners. Product specifications subject to change without notice. Printed in the USA. UG-ECHO-EXP3FD-E-E-102715



Statement of Conformity

Sonnet Technologies, Inc.
8 Autry
Irvine, CA 92618
USA

Declare under our sole responsibility that the product(s):

Product Name: Echo Express III
Product Model(s): Echo Express III-D
Echo Express III-R

To which this declaration relates is in conformity with the requirements of the following specifications:

ANSI C63.4-2009
FCC 47 CFR Part 15, Subpart B, Class B Digital Device.
ICES-003 Issue 5

Supplementary information:

This device complies with part 15 of the FCC Rules. Operation is subject to the following two conditions: (1) This device may not cause harmful interference, and (2) this device must accept any interference received, including interference that may cause undesired operation.

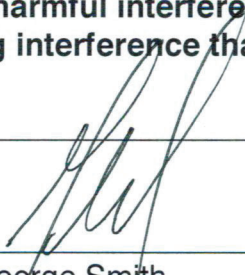
Signed by or for manufacturer:	
	Name: George Smith
	Title: Director of Hardware Development
	Place and Date: Sugar Hill, GA USA, September 22, 2014



EC Declaration of Conformity

In accordance with EN ISO 17050-1:2004

Manufacturer's Name: Sonnet Technologies, Inc.

Manufacturer's Address: 8 Autry
Irvine, CA 92618
USA

In accordance with Directive(s):
LVD (2006/95/EC).
EMC Directive (2004/108/EC)

hereby declare, that the product

Product Name: Echo Express III
Product Number(s): Echo Express III-D
Echo Express III-R

Conforms to the following Product Specifications:

Safety: IEC 60950-1:2005/A1:2009, EN 60950-1:2006/A11:2009/A1:2010/A12:2011/AC:2011

EMC: EN 55022:2010
EN 55024:2010
EN 61000-3- 2:2006 w/A1:2009 and A2:2009
EN 61000-3- 3:2008

I hereby declare that the equipment named above has been designed to comply with the relevant sections of the above referenced specifications. The unit complies with all applicable Essential Requirements of the Directives.

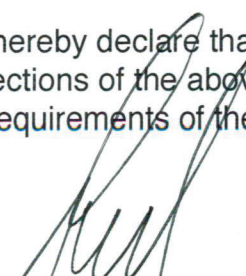

George Smith, Director of Hardware Development

Sugar Hill, GA USA
September 22, 2014