

Thunderbolt 3 Upgrade

Quick Installation Instructions for Echo Express III-R



Support Note: To avoid damaging components due to static electricity discharge, wear an antistatic wrist strap while working inside the Echo Express chassis.

Note that these illustrations show the Echo chassis with PCIe cards removed, but it is not necessary for you to remove them.



WARNING: When handling computer products, take care to prevent components from being damaged by static electricity; avoid working in carpeted areas. Handle expansion cards only by their edges and avoid touching connector traces and component pins. Also, avoid touching the Echo chassis' circuit boards and any of its components.



WARNING: Connection of your upgraded Echo chassis to a Thunderbolt 3 computer requires the use of a Thunderbolt 3 (40Gbps) cable, which features both a Thunderbolt icon (⚡) AND the number 3 on the connector housings. **Similar-looking cables without the Thunderbolt icon on its connectors are USB cables, and do not support connection of the Echo chassis to your computer.**



SIMPLY FAST™

©2017 Sonnet Technologies, Inc. All rights reserved. Sonnet, the Sonnet logotype, Simply Fast, the Simply Fast logotype, and Echo are trademarks of Sonnet Technologies, Inc. Thunderbolt 3 and the Thunderbolt logo are trademarks of Intel Corporation in the U.S. and/or other countries. Other product names are trademarks of their respective owners. Product specifications subject to change without notice. QS-BRD-UPGRTB3-E3R-E-B-072417

1. Disconnect any cables connected to the Echo chassis.
2. Using a Phillips screwdriver, remove and set aside the five screws securing the outer case to the inner assembly. If your Echo chassis uses thumbscrews instead of standard screws, loosen them instead.

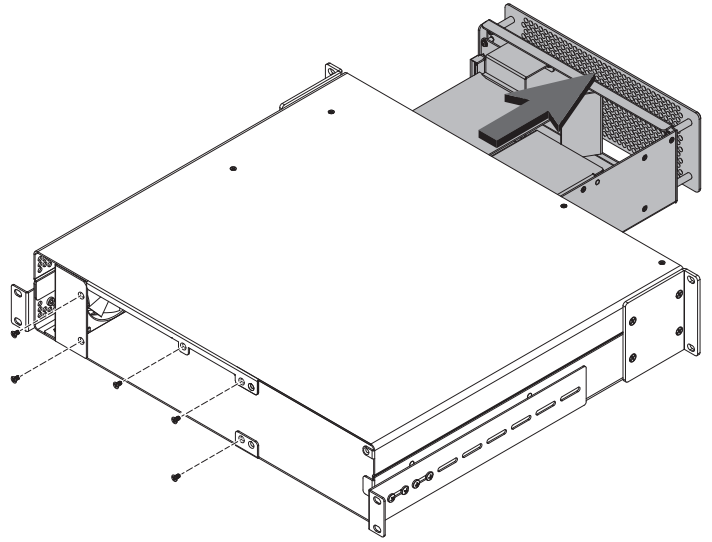

3. Push the inner assembly into the outer case, and then gently pull out the inner assembly. Set the inner assembly on a flat, level surface.

1

4. Remove and set aside the two screws securing the Thunderbolt interface card to the inner assembly.

5. Gently push down on the edge of the card to disengage it from the slot.

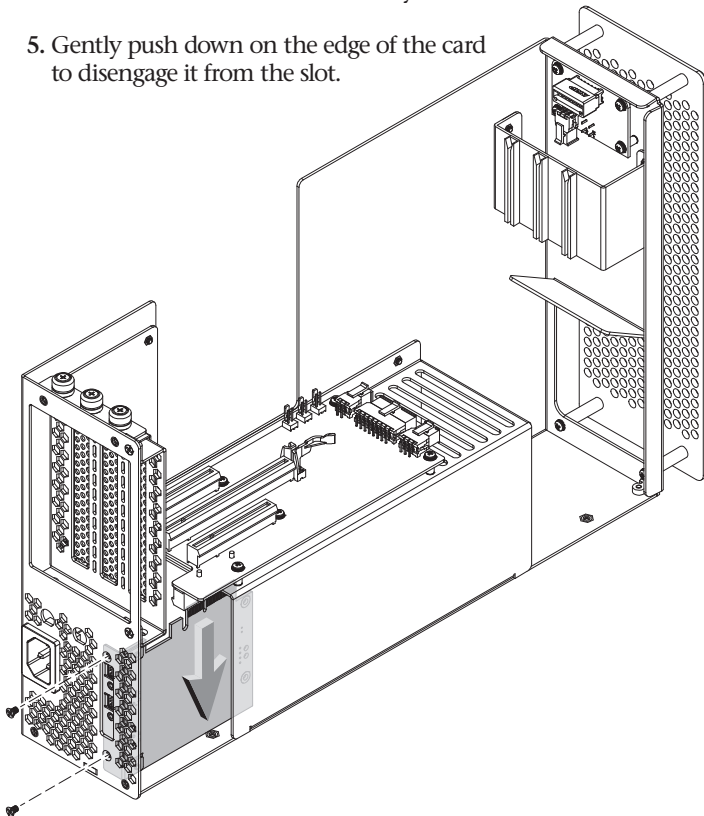

2

6. Grasping the card by its edges, rotate the bracket out of the inner assembly, and then pull out the card. Set aside the card on flat surface, component side down.

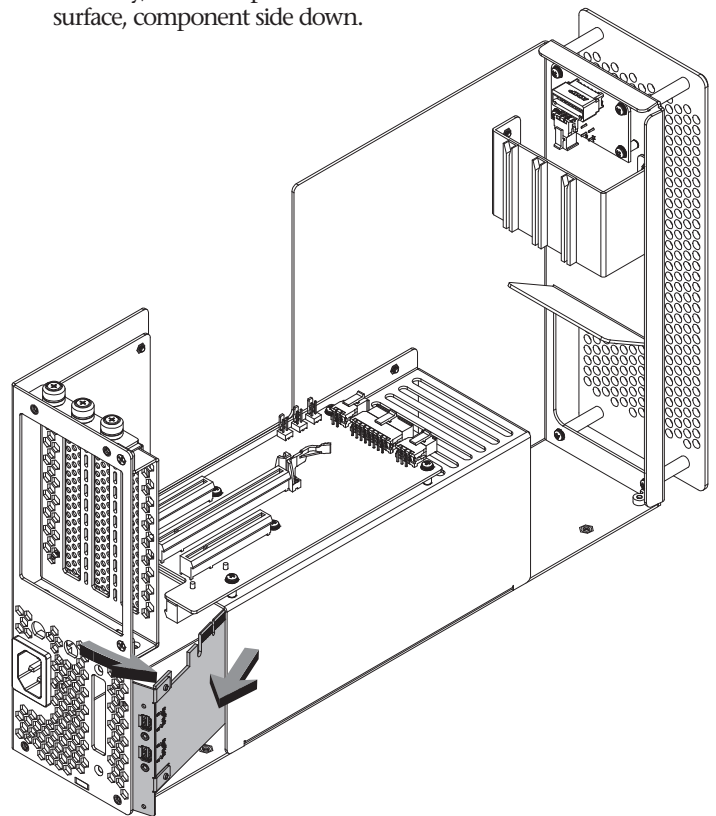

3

7. Remove the Thunderbolt 3 upgrade card from its packaging, handling the card by its bracket.

8. Grasping the Thunderbolt 3 upgrade card by its edges, insert the card into the inner assembly.

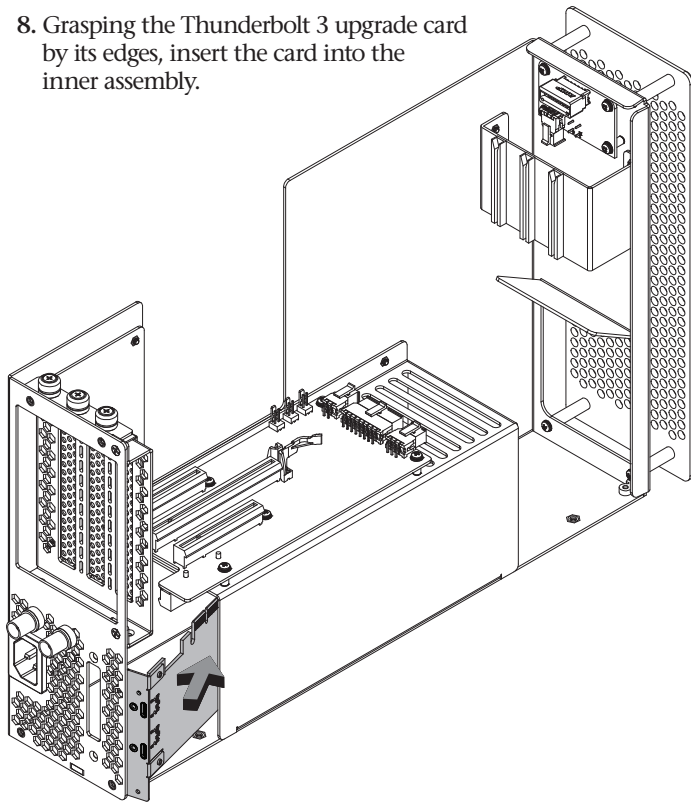

4

9. Line up the card's connector with the slot, and then gently but firmly press the card straight into the slot; **do not rock the card or force the card into the slot**. If you encounter excessive resistance, check the card's connector and the slot for damage, and then try inserting the card again.

10. Using the two screws you removed previously, secure the Thunderbolt interface card to the inner assembly; **do not overtighten the screws**.

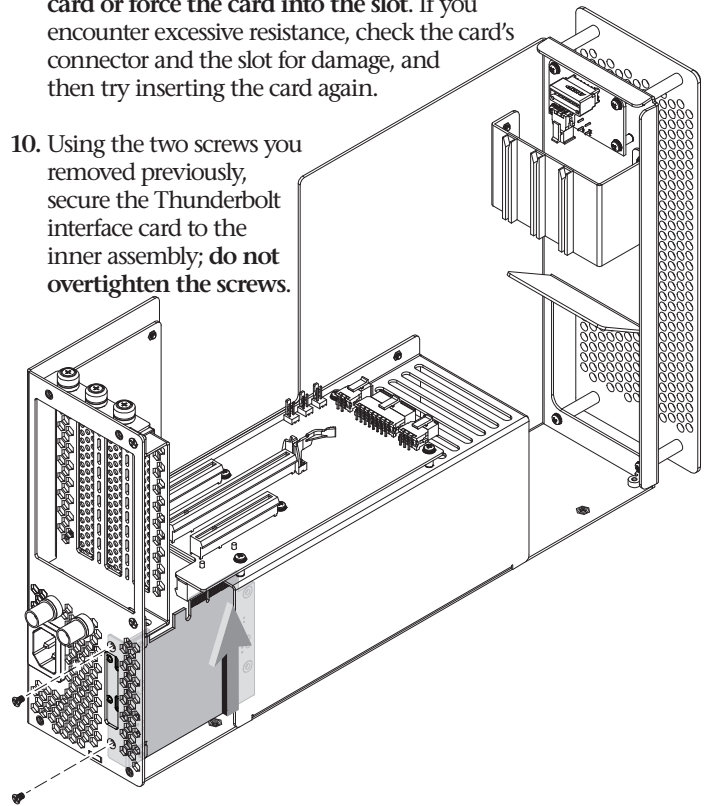

5

11. Insert the inner assembly back inside the outer case.

12. Secure the outer case to the inner assembly using the five screws you removed previously (or tighten the five thumbscrews); your upgrade is complete.

13. Connect the Echo chassis to your computer with a Thunderbolt 3 (40Gbps) cable (sold separately), and then reconnect any other cables to the chassis.

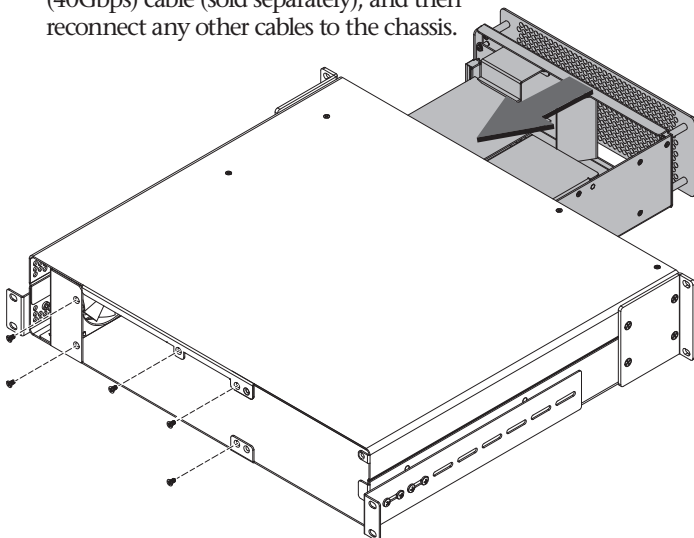

14. Place the Thunderbolt 2 interface card in the upgrade card's packaging and set it aside for safe keeping.

6

Limited Warranty

For complete warranty information, go to www.sonnettech.com/support/warranty.html

Contacting Customer Service

The Sonnet Web site located at www.sonnettech.com has the most current support information and technical updates. Before you call Customer Service, please check our Web site for the latest updates and online support files, and check this Quick Start Guide for helpful information.

When you call Customer Service, have the following information available so the customer service staff can better assist you:

- Product name
- Date and place of purchase
- Computer model

USA Customers

If further assistance is needed, please contact Sonnet Customer Service at:

Tel: 1-949-472-2772

(Monday–Friday, 7 a.m.–4 p.m. Pacific Time)

E-mail: support@sonnettech.com

For Customers Outside the USA

For support on this product, contact your reseller or local distributor.

Visit Our Web Site

For the most current product information and online support files, visit the Sonnet web site at www.sonnettech.com. Remember to register your product online at <http://registration.sonnettech.com> to be informed of future upgrades and product releases.