

# Quick Start Guide

for Sonnet SF3™ Series — AJA® PAK Media Pro Card Reader

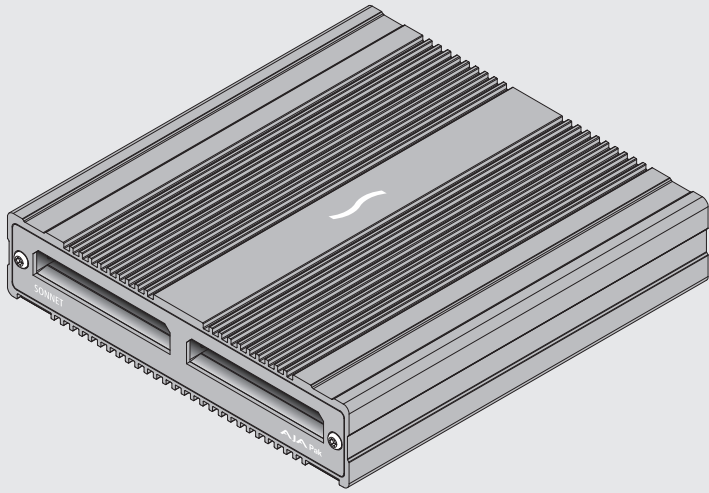

## Mac® Compatibility

- Mac (M series)
- Mac (Intel®) with Thunderbolt 3 ports
- Mac with a Thunderbolt 2 port with an Apple Thunderbolt 3 (USB-C) to Thunderbolt 2 Adapter plus a Thunderbolt cable (sold separately)
- macOS® 10.12.6+

## Windows® Compatibility

- Computer with Thunderbolt 5, 4 or 3 ports
- Windows 11, 10

## AJA PAK Media Compatibility

- All PAK Media cards



**Support Note:** This document was up to date at the time of printing. Please check the Sonnet website for the latest documentation.

1. Go to <https://www.sonnettech.com/support/kb/kb.php>
2. Navigate to and click the SF3 Series AJA PAK Media Pro Card Reader link.
3. Click the Manual link.
4. Click the SF3 Series AJA PAK Media Pro Card Reader QSG [English] link and then check the Document Version information. If the version listed is later than this document (**revision C**), click the Download Now button for the latest version.

1

## Card Reader Description

### 1 – Card Slots

These slots accept all AJA PAK Media cards.

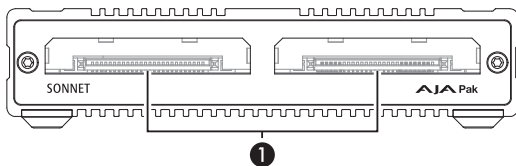

### 2 – Thunderbolt Ports

Connect the included (or other certified) Thunderbolt cable between either of these ports and your computer's (or intermediate peripheral device's) Thunderbolt port; the open port may be used to connect another Thunderbolt peripheral device.

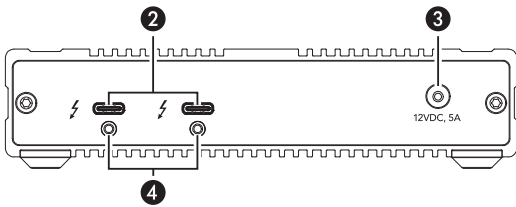

### 3 – 12VDC Socket

Connect the included DC power adapter to this connector.

### 4 – Threaded Nut for ThunderLok

Attach the included Thunderbolt connector retainer clip here.

2

## Additional Package Contents Description

### Power Adapter and Power Cord

Connect the power adapter to Sonnet card reader's 12VDC socket. Connect the power cord between a power outlet and the power adapter. Note that the power cord included with your product may appear different than the one pictured here, depending on where the product was purchased.

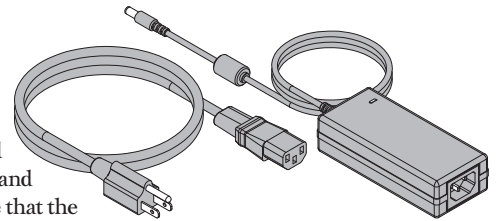

### Thunderbolt Cable

Connect this cable between the Sonnet card reader and one of your computer's Thunderbolt ports (often indicated by a lightning bolt logo), or other Thunderbolt peripheral device in the chain connected to the computer. Ports marked with the generic USB icon (⏏) or USB Charging Port icon (⚡) are NOT compatible.

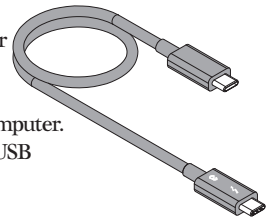

### ThunderLok™ Thunderbolt Connector Retainer Clip

This clip secures the included Thunderbolt cable's connector plugged into one of the Sonnet card reader's Thunderbolt ports to prevent accidental cable disconnection. This clip is compatible with Sonnet 0.5- and 0.7-meter Thunderbolt cables.

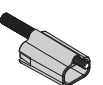

3



**Support Note:** To attach the ThunderLok clip to the cable, remove both from their packaging, and then insert the connector through the connector clip as shown. Note that the connector will pass all the way through the clip; when you connect the cable to the reader, the clip will secure the connector.

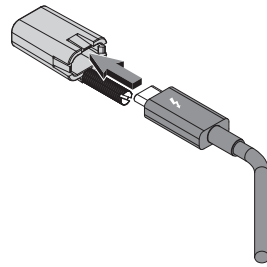

### Connecting the Reader

1. Connect the included (or other certified) Thunderbolt cable between either Thunderbolt port on the Sonnet card reader and a Thunderbolt port on your computer, or other Thunderbolt peripheral device in the chain connected to the computer. Secure the retainer clip to the reader if you attached it to the cable.
2. Connect the included power cord between a wall outlet or power strip and the power adapter; verify the connector is plugged in securely. Connect the power adapter cable to the card reader's 12V power connector.

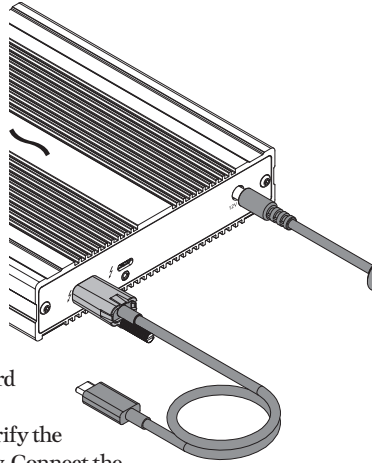

4

### Windows Users—Using the Card Reader For the First Time

An *Approve New Thunderbolt™ Devices* window will appear the first time you connect Sonnet card reader to your computer while it is running (or the first time your computer boots with the reader connected). From the drop-down menu select Always Connect, and then click OK.

### All Users—Inserting and Removing Cards

- To insert a card, push it into straight into the slot, parallel to the top cover of the reader, until it stops; do not force a card into the slot, as you may damage the card or the slot connector.
- Before removing a card, be sure to “eject” or “Safely Remove” its mounted volume; otherwise, data on the memory card may be corrupted.
- To remove a card, pull it straight out of the slot.

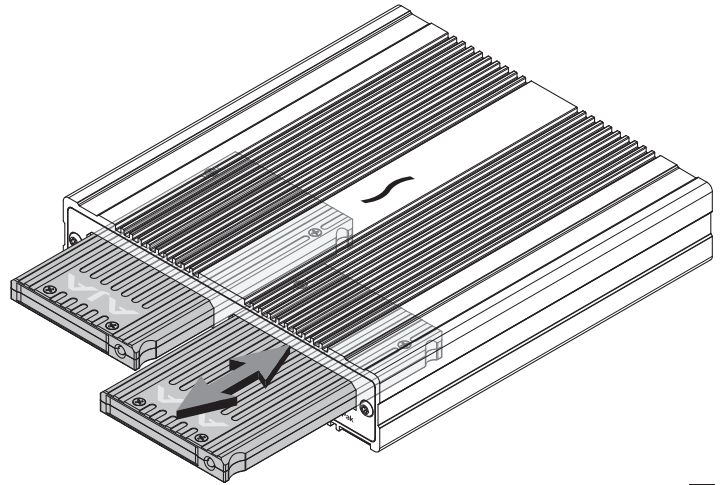

5

### Contacting Customer Service

The Sonnet Web site located at [www.sonnettech.com](http://www.sonnettech.com) has the most current support information and technical updates. Before contacting Customer Service, please check our Web site for the latest updates and online support files, and check this Quick Start Guide for helpful information.

Email support requests generally receive the fastest responses, and are usually processed within a 24-hour period during normal business hours, excluding holidays. When you contact Customer Service, have the following information available so the customer service staff can better assist you:

- Product name
- Date and place of purchase
- Computer model
- OS version
- A System Report (macOS) or a Microsoft System Information MSINFO32 (Windows) report (Windows), along with a description of the issue(s) you are encountering with your device.

If further assistance is needed, contact Sonnet Customer Service at:

**E-mail:** [support@sonnettech.com](mailto:support@sonnettech.com)

**Tel:** 1-949-472-2772

(Monday–Friday, 9 a.m.–5 p.m. Pacific Time, excluding holidays)

### Japan Customers

Contact Sonnet Customer Service Japan at:

**E-mail:** [jp.support@sonnettech.com](mailto:jp.support@sonnettech.com)

6



©2024 Sonnet Technologies, Inc. All rights reserved. Sonnet, SONNETTECH, the Sonnettech logotype, and the S logotype are registered trademarks of Sonnet Technologies, Inc. SF3 and ThunderLok are trademarks of Sonnet Technologies, Inc. Mac, the Mac logo, and macOS are trademarks of Apple Inc., registered in the United States and other countries. Thunderbolt and the Thunderbolt logo are trademarks of Intel Corporation in the U.S. and/or other countries. Other product names are trademarks of their respective owners. Product specifications subject to change without notice. QS-SF3-2AJAPK-E-C-091124