

Thunderbolt 3 Upgrade Kit

Quick Installation Instructions for xMac mini Server



Support Note: To avoid damaging components due to static electricity discharge, wear an antistatic wrist strap while working inside the xMac mini server enclosure.

Note that some illustrations show the xMac mini Server with PCIe cards removed, but it is not necessary for you to remove them.



WARNING: When handling computer products, take care to prevent components from being damaged by static electricity; avoid working in carpeted areas. Handle expansion cards only by their edges and avoid touching connector traces and component pins. Also, avoid touching the Echo chassis' circuit boards and any of its components.

SONNET™

SIMPLY FAST™

©2019 Sonnet Technologies, Inc. All rights reserved. Sonnet, the Sonnet logotype, Simply Fast, the Simply Fast logotype, and Echo are trademarks of Sonnet Technologies, Inc. Thunderbolt 3 and the Thunderbolt logo are trademarks of Intel Corporation in the U.S. and/or other countries. Other product names are trademarks of their respective owners. Product specifications subject to change without notice. QS-BRD-UPGRTB3-XM-E-A-050719

1. Loosen the two captive thumbscrews securing the top cover to the rest of the xMac mini Server.

2. Lift the top cover up and slide it back to remove it.

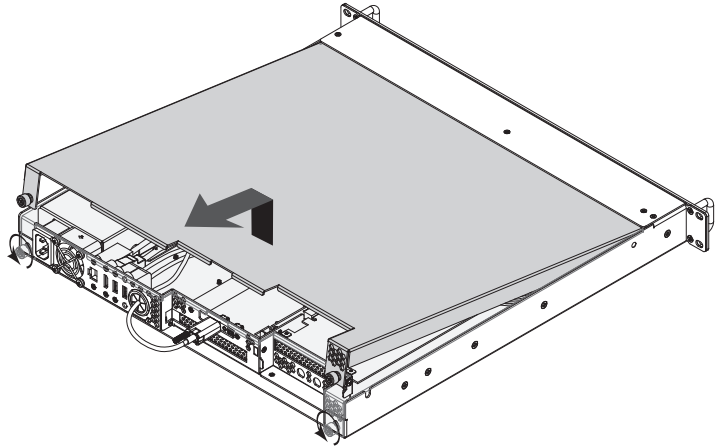

1

3. Disconnect the cables plugged in to the old Mac mini, and then remove the computer from the enclosure.

4. Remove and set aside the two screws securing the Thunderbolt interface card to the back of the enclosure.

5. Remove and set aside the two screws securing the right-most USB-A port to the back of the enclosure, and then remove the cable; it will not be connected to the new computer.

6. Disconnect the Thunderbolt cable from the Thunderbolt interface card, and then remove the cable from the enclosure.

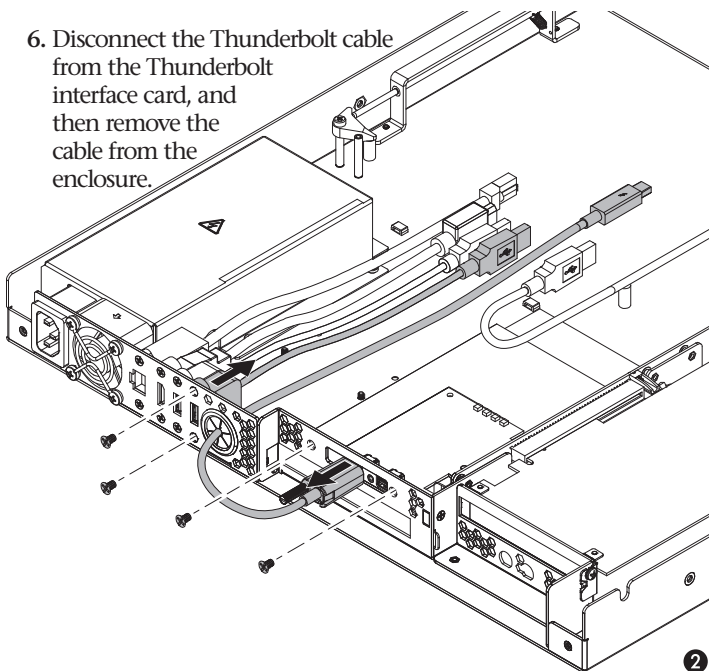

2

7. Grasping the Thunderbolt interface card by its edges, pull out the card from its slot. Set aside the card on flat surface, component side down.

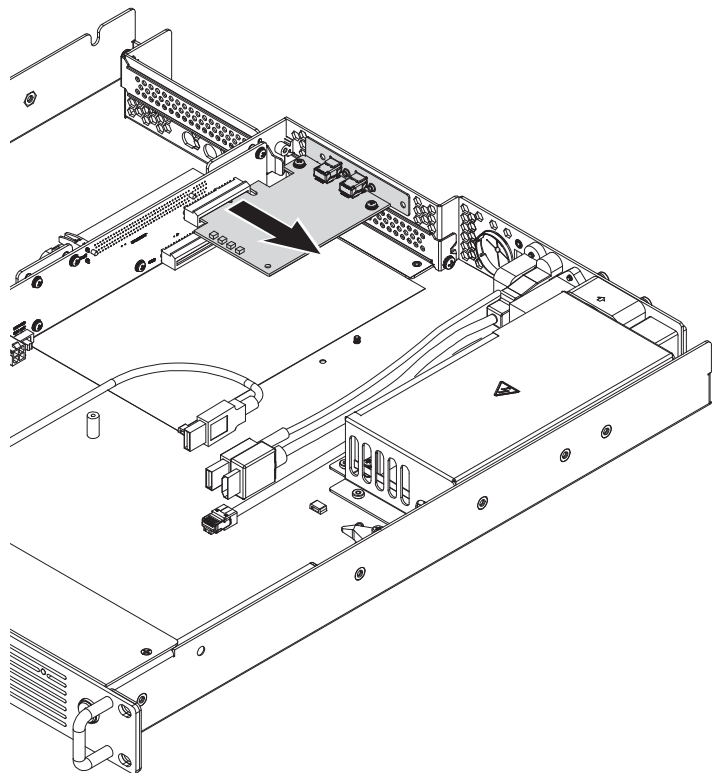

3

8. Remove the Thunderbolt 3 upgrade card from its packaging, handling the card by its bracket.
9. Line up the Thunderbolt 3 interface card's connector with the slot, and then gently but firmly press the card into the slot; **do not rock the card or force the card into the slot**. If you encounter excessive resistance, check the card's connector and the slot for damage, and then try inserting the card again.

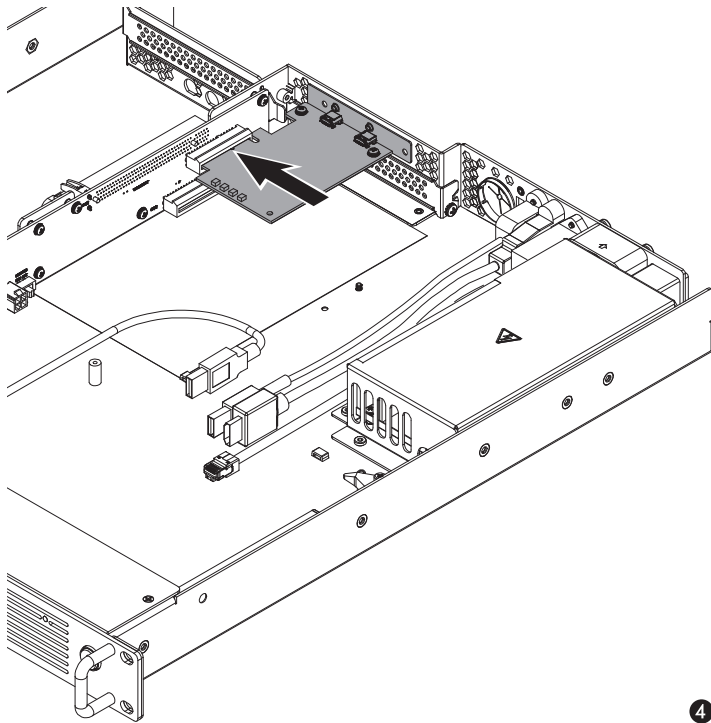

4

10. Using the two screws you removed previously, secure the Thunderbolt 3 interface card to the enclosure; **do not overtighten the screws**.
11. Remove the included Thunderbolt 3 (40 Gbps) cable and ThunderLok 3 retainer clip from their packaging, and then insert the cable through the clip.
12. Connect and secure one end of the Thunderbolt 3 cable to either one of the Thunderbolt 3 interface card's ports, and then route the other end of the cable through the external cable passthrough opening.

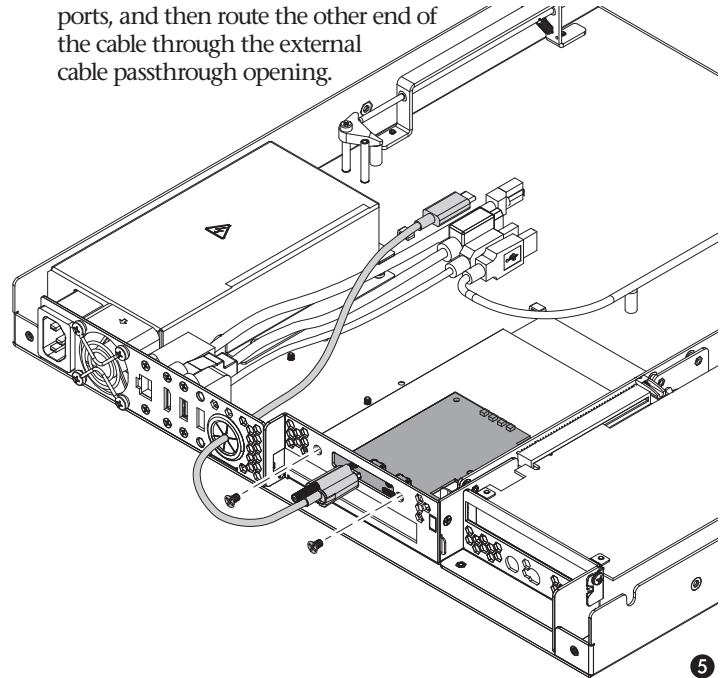

5

13. Remove the new Mac mini from its packaging.
14. Carefully insert the Mac mini under the top edge of the enclosure, push it against the gasket behind the enclosure's face plate, and then lower the computer onto the floor behind the small plastic posts.
15. Plug all of the xMac mini Server's cables into the back of the Mac mini, and other cables into PCIe cards as necessary; **verify the cables are plugged in securely**.

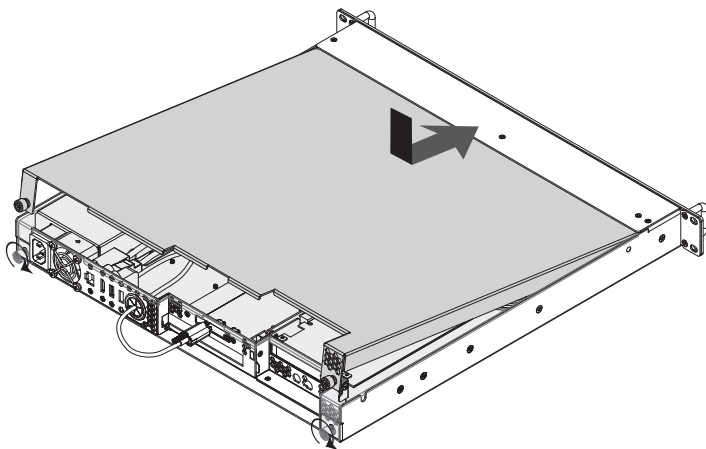

6

16. Insert the top cover under the top edge of the enclosure, lower the lid, and then secure it with the captive thumbscrews; your upgrade is complete.

Contacting Customer Service

The Sonnet Web site located at www.sonnettech.com has the most current support information and technical updates. Before you call Customer Service, please check our Web site for the latest updates and online support files, and check this User's Guide for helpful information.

Email support requests generally receive the fastest responses, and are usually processed within a 24-hour period during normal business hours, excluding holidays. When you contact Customer Service, have the following information available so the customer service staff can better assist you:

- Product name • Date and place of purchase • Computer model
- PCIe card models • Operating system version
- Software/firmware versions • A macOS System Report

USA Customers

If further assistance is needed, please contact **Sonnet Customer Service** at:

Tel: 1-949-472-2772

(Monday–Friday, 7 a.m.–4 p.m. Pacific Time)

E-mail: support@sonnettech.com

For Customers Outside the USA

For support on this product, contact your reseller or local distributor.

Visit Our Web Site

For the most current product information and online support files, visit the Sonnet Web site at www.sonnettech.com/support/. Register your product online at <https://registration.sonnettech.com> to be informed of future upgrades and product releases.